

Actuator Series Closing Gripper Series

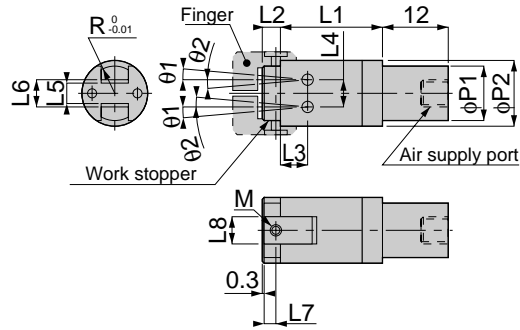

Shank Type



unit:mm

Model	M	R	L1	L2	L3	L4	L5	L6	L7	L8	φP1	φP2	θ1	θ2	Mass (g)
CHM 08AAK	M2×0.4	R5	19.5	3	5	5	4	5	2	5	10	12	10°	4.5°	21.5
CHM 11AAK	M2.5×0.45	R6.5	23.5	4	5.5	6	4.5	6	2.5	7	12	16	8°	4.5°	41



1



Panel Mount Type

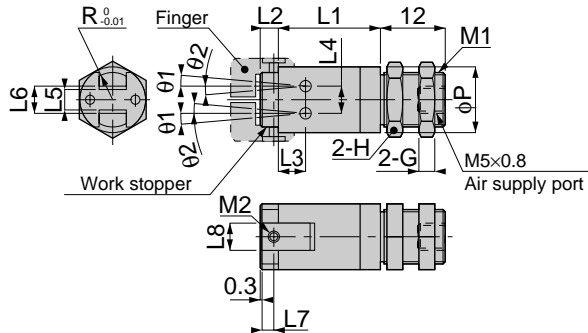

unit:mm

Model	M1	M2	R	L1	L2	L3	L4	L5	L6	L7	L8	φP	θ1	θ2	H	G	Mass (g)
CHM 08ABK	M10×1	M2×0.4	R5	19.5	3	5	5	4	5	2	5	12	10°	4.5°	12	3	22
CHM 11ABK	M12×1	M2.5×0.45	R6.5	23.5	4	5.5	6	4.5	6	2.5	7	16	8°	4.5°	14	4	43.5



1



Floating Panel Mount Type Fingers in Parallel

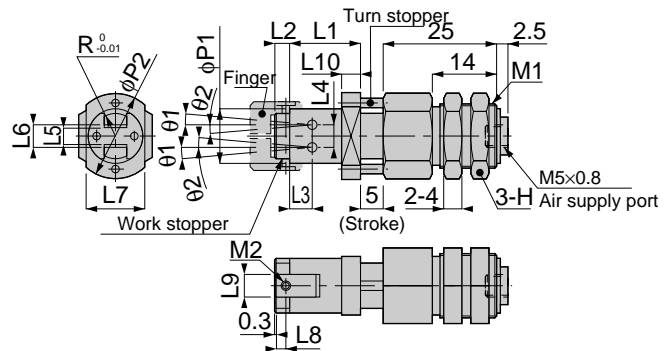

unit:mm

Model	M1	M2	R	L1	L2	L3	L4	L5	L6	L7	L8	L9	L10	φP1	φP2	θ1	θ2	H	Mass (g)
CHM 08ACK	M14×1	M2×0.4	R5	15.5	3	5	5	4	5	13	2	5	4	12	19	10°	4.5°	17	58
CHM 11ACK	M18×1	M2.5×0.45	R6.5	18.5	4	5.5	6	4.5	6	17	2.5	7	5	16	24	8°	4.5°	22	104.5



1



Floating Panel Mount Type Fingers at Right Angle

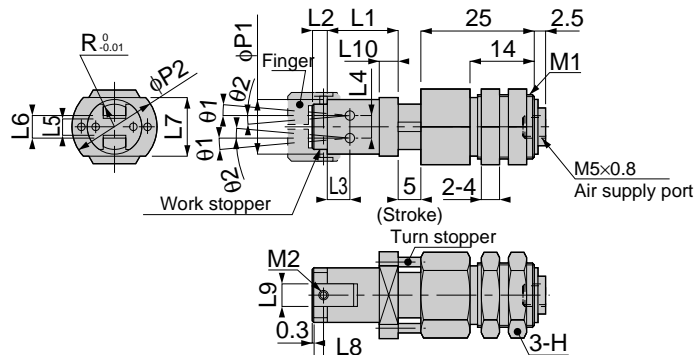

unit:mm

Model	M1	M2	R	L1	L2	L3	L4	L5	L6	L7	L8	L9	L10	φP1	φP2	θ1	θ2	H	Mass (g)
CHM 08ADK	M14×1	M2×0.4	R5	15.5	3	5	5	4	5	13	2	5	4	12	19	10°	4.5°	17	58
CHM 11ADK	M18×1	M2.5×0.45	R6.5	18.5	4	5.5	6	4.5	6	17	2.5	7	5	16	24	8°	4.5°	22	104.5



1