

Control Series Fiber Dry

FDT 100

Dry unit (Filter, Dryer)

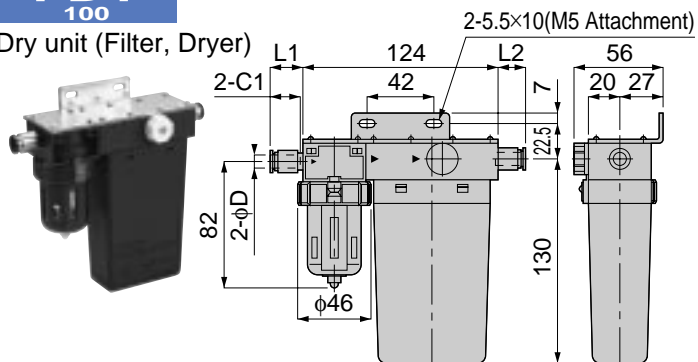

unit:mm

Model	Tube dia. φD	L1	L2	C	Mass (g)
FDT 100-4	4	9.5	6	11	443
FDT 100-4-A					445
FDT 100-6	6	12.5	9	12	443
FDT 100-6-A					445
FDT 100-8	8	20.5	17	18.5	449
FDT 100-8-A					451
FDT 100-10	10	25.5	22	21	459
FDT 100-10-A					461

DMP 100

Dryer

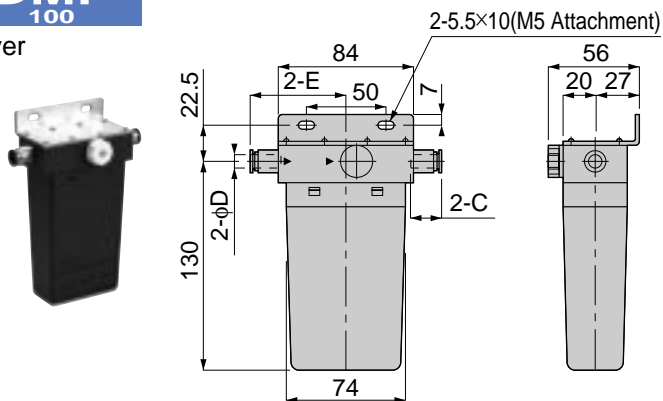

unit:mm

Model	Tube dia. φD	C	E	Mass (g)
DMP 100-4	4	11	48	327
DMP 100-6	6	12	51	327
DMP 100-8	8	18.5	59	340
DMP 100-10	10	21	64	359

FDT, DMP Dehumidification Performance Curve (Example)

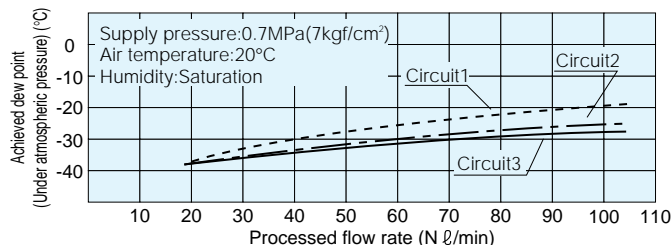

FDT, DMP Purging flow rate curve

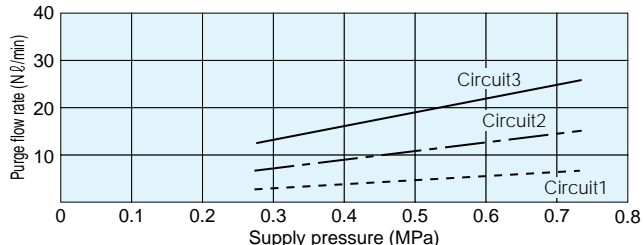

FFT

Filter

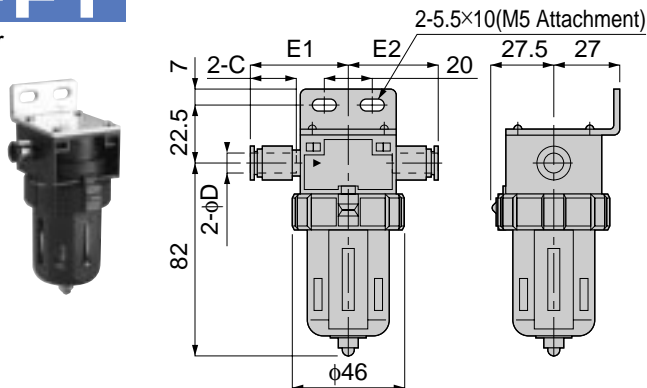

unit:mm

Model	Tube dia. φD	C	E1	E2	Mass (g)
FFT 100-4	4	11	29.5	26	132
FFT 100-4-A					134
FFT 100-6	6	12	32.5	29	132
FFT 100-6-A					134
FFT 100-8	8	18.5	40.5	37	145
FFT 100-8-A					147
FFT 100-10	10	21	45.5	42	164
FFT 100-10-A					166

Manual draining Automatic draining

