

Control Series Fiber Dry

DMM 040

Dryer

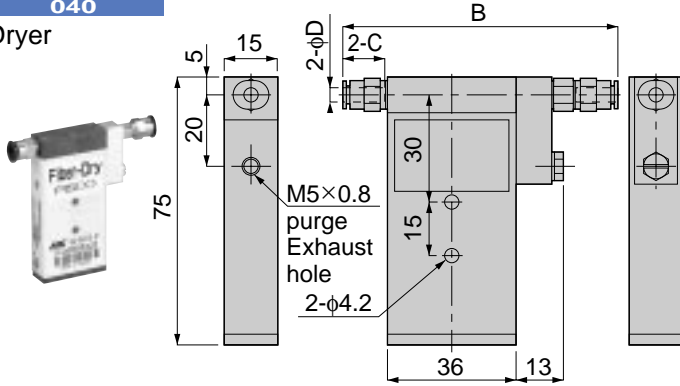

Model	Tube dia. ϕD	B	C	Mass (g)
DMM 040-4-□	4	77.5	11	65
DMM 040-6-□	6	80.5	11.5	68

※ DMM-040 does not have purging flow rate adjusting function. Therefore select one from the three types in consultation with the graphs.

Processed flow rate (outlet flow rate)
Code 1: 16 N ℓ/min.
2: 30 N ℓ/min.
3: 40 N ℓ/min.

Dehumidification Performance Curve (Example)

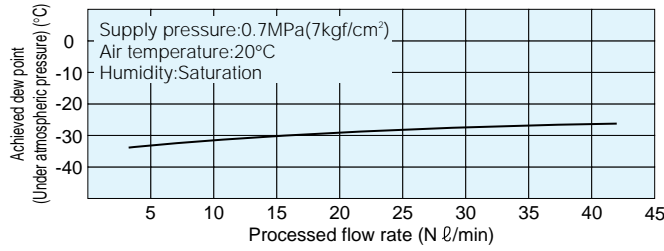

Purging flow rate curve

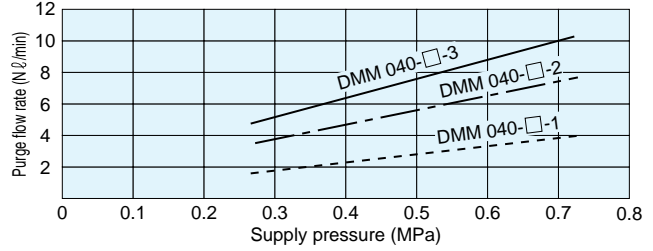

DMB 100

Dryer

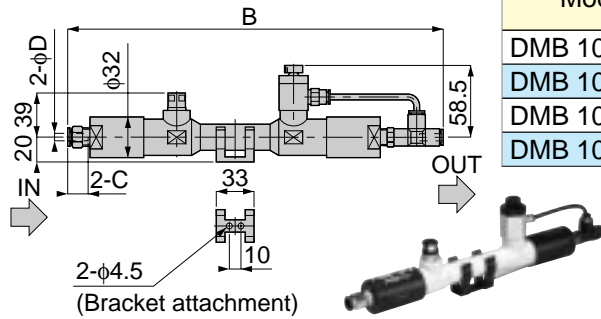

Model	Tube dia. ϕD	B	C	Mass (g)
DMB 100-4	4	294	15	307
DMB 100-6	6	302	17	302
DMB 100-8	8	307	18	316
DMB 100-10	10	321	21	333

Dehumidification Performance Curve (Example)

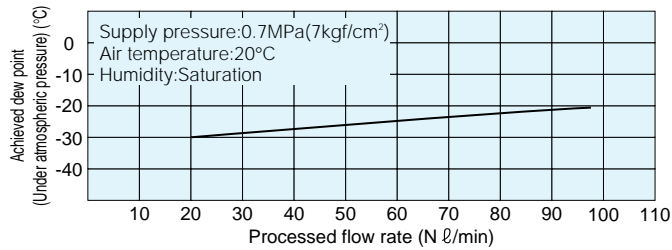

Purging flow rate curve

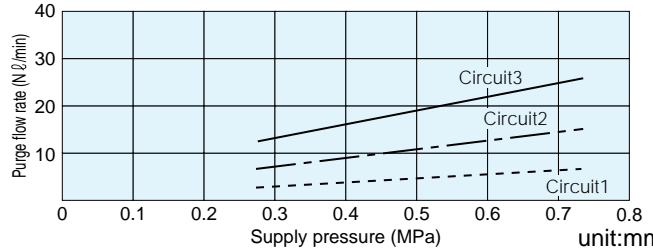

DMB 500

Dryer

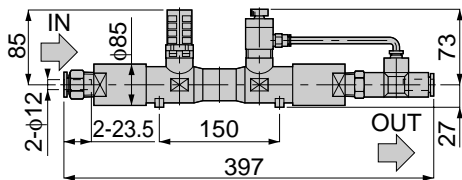

Model	Mass (g)
DMB 500-12	846

Dehumidification Performance Curve (Example)

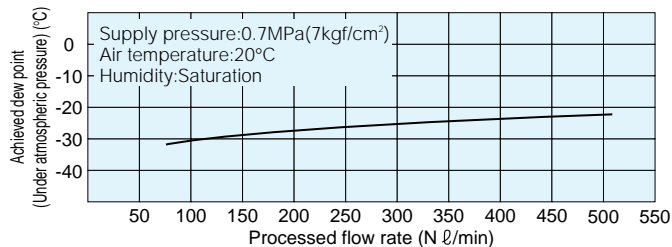

Purging flow rate curve

